

Manifolds - Three Valve

Differential pressure manifolds with two 3/8" (9.5 mm) orifice soft or metal-seated block valves and a metal seated equalizer valve for direct or remote mounting at pressures to 6000 psig (414 barg)

General Application

The M45A is designed for mounting on differential pressure transmitters with 2 1/8" (54 mm) center-to-center connections.

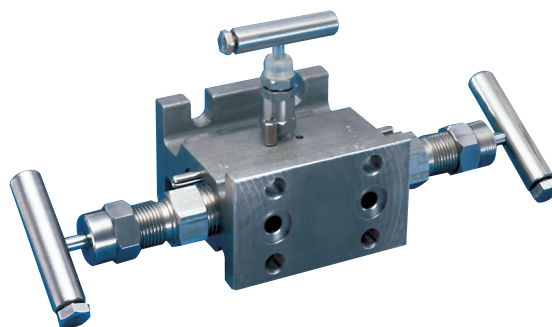

TECHNICAL DATA

Materials

CS, 316 SS

Seats:

Metal or soft

Connections:

Instrument: Flanged

Process: Flanged

Pressure (max):

6000 psig (414 barg)

Temperature range (min/max):

-70°F to 1000°F

(-57°C to 538°C)

Features

- Cost savings of 20-30% when unitizing the manifolding by eliminating several parts used in conventional methods of 'piping up'.
- Roddable block valve seats simplify maintenance and ensure accuracy.
- Back seat stem design eliminates stem blowout or accidental removal while in operation.
- Fewer leak points reduce the chances of leakage.
- Seat design enables field replacement without valve removal.
- Integral hard back seat protects against stem blowout and provides a secondary packing seal.
- Rolled stem threads provide a stronger, more durable thread area, increasing valve life.
- Mirror stem finish in the packing area enables smooth operation and extends packing life.
- Constant compression metal-to-metal bonnet-to-body seal below bonnet threads prevents corrosion, eliminates tensile breakage and creates a reliable seal point.
- Easily adjustable stem packing decreases downtime and provides long service life.
- Manifold mounts directly to the pipe stand. AGCO mount supports the transmitter, allows loop installation without the transmitter and easy removal for service or repair.

M45A SERIES

Manifolds - Three Valve

M45A Dimensions

Dimensions, inches [mm]

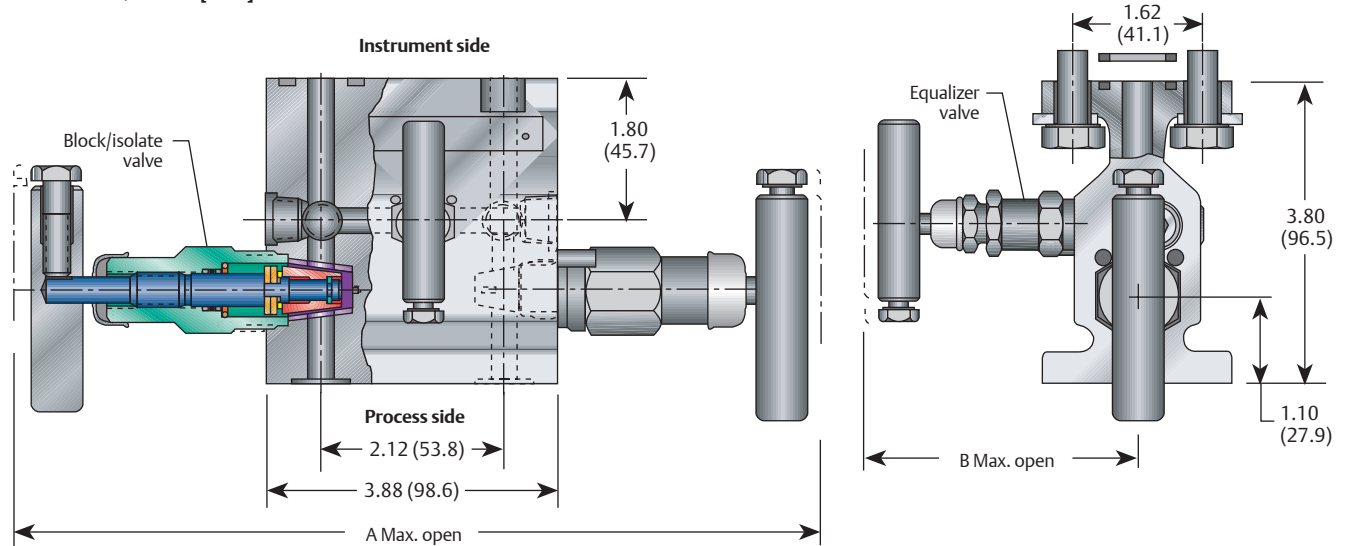

Dimensions, inches (mm)

Packing	A	B
PTFE	11.90 (302.3)	3.40 (86.4)
GRAFOIL®	11.90 (302.3)	4.05 (102.9)
O-ring	11.36 (288.5)	3.40 (86.4)

NOTE

1. Bottom static (test) connection available.

Mounting

For direct or remote mounting, the M45A permits the transmitter's flange to connect the process signal lines to the manifold directly, with either ½" pipe or tubing connections.

Bonnet Assemblies

The M45A features two block valves with roddable soft or metal seats and a metal-seated equalizer valve. All stem threads are ENC plated, rolled and lubricated to prevent galling and reduce operating torque. All bonnets are assembled with a bonnet locking pin to prevent accidental removal while in service and a protective dust cap is fitted to contain stem lubricant and prevent the influx of contaminants.

Soft-seated Bonnet Assemblies

The soft-seated block valve bonnet assemblies have a non-rotating plug. In addition to the adjustable PTFE packing gland, the bonnets are available with a FKM O-ring and PTFE back-up ring.

Metal-seated Bonnet Assembly

The metal-seated block bonnet assembly has a non-rotating plug for long bubble tight shut off. The high-temperature bonnet assembly uses a strengthened stem and bonnet incorporating adjustable graphite O-rings and back-up pressure rings to ensure a leak-free stem seal and is fitted with a larger size T-bar handle.

Manifolds - Three Valve

Standard Materials

Valve ^[1]	Bonnet			
	Body	Block Valve	Equalizer Valve ^[2]	Stem
CS ^[4]	A105	A108	A108	A581-303
CS ^[4]	A105	A108	A105	A581-303
316 SS	A479-316	A479-316	316	A276-316
316 SS	A479-316	A479-316	316	A276-316
SG ^[5]	A479-316	A479-316	316	Monel [®]
SG3 ^[6]	Hastelloy [®] C276	Hastelloy [®] C276	Hastelloy [®] C276	Hastelloy [®] C276

Pressure and Temperature Ratings

Valve	Packing	Seat	Pressure and temperature ratings
CS ^[4]	PTFE	Delrin [®] [3]	6000 psig at 200°F (414 barg at 93°C)
CS ^[4]	GRAFOIL [®]	316 SS	1500 psig at 850°F (103 barg at 454°C)
316 SS	PTFE	Delrin [®]	6000 psig at 200°F (414 barg at 93°C)
316 SS	GRAFOIL [®]	316 SS	1500 psig at 1000°F (103 barg at 538°C)
SG ^[5] , SG3 ^[6]	PTFE	Delrin [®] [3]	6000 psig at 200°F (414 barg at 93°C)

Minimum Temperature

Carbon steel	-20°F (-29°C)
316 SS O-ring seal	-20°F (-29°C)
316 SS, Monel [®] , Hastelloy [®]	-70°F (-57°C)
PTFE packed	
Delrin [®] seat	-40°F (-40°C)
316 SS, Monel [®] , Hastelloy [®]	-70°F (-57°C)
GRAFOIL [®] packed	

NOTES

- Approximate valve weight: 7.1 lb (3.2 kg).
0.375-inch (9.5 mm) diameter orifice.
Valve Cv 3.0 maximum.
- Equalizer valve utilizes free-swiveling ball ended stem. Equalizer orifice size 0.187-inch (4.8 mm).
- PCTFE (Polychlorotrifluoroethylene is exact equivalent of Kel-F[®]), PEEK and PTFE also available.
- CS is zinc TCP plated to resist corrosion.
- SG (Sour Gas) meets the requirements of NACE MR0175/ISO 15156 (for chloride conditions ≤ 50 mg/l [ppm]) and NACE MR0103.
- SG3 (Sour Gas) meets the requirements of NACE MR0175/ISO 15156 (for chloride conditions > 50 mg/l [ppm]).
- 316 SS bolts lower pressure ratings to a maximum of 4500 psi (310 barg). Consult factory for full rating with 316 SS bolts.

Pressure vs. Temperature

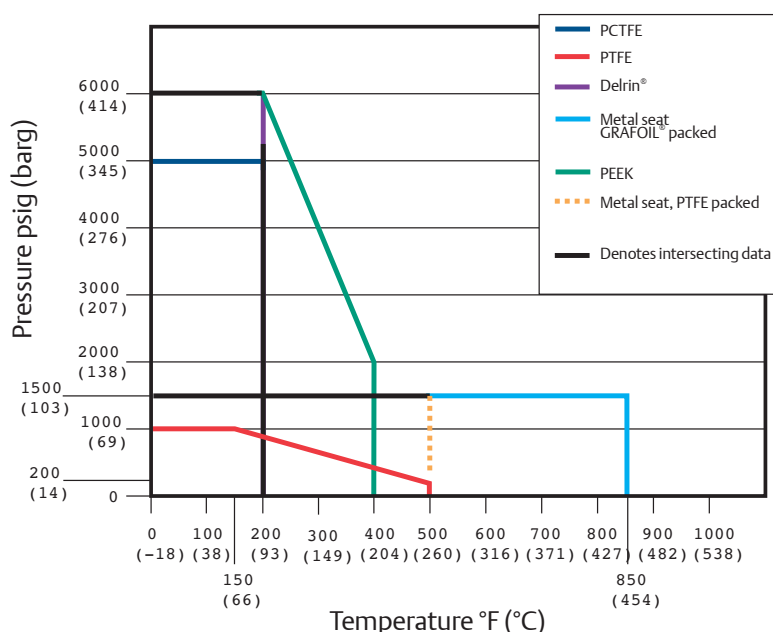

M45A SERIES

Manifolds - Three Valve

M45A Dimensions

AGCO Mount with M45A manifold dimensions, inches (mm)

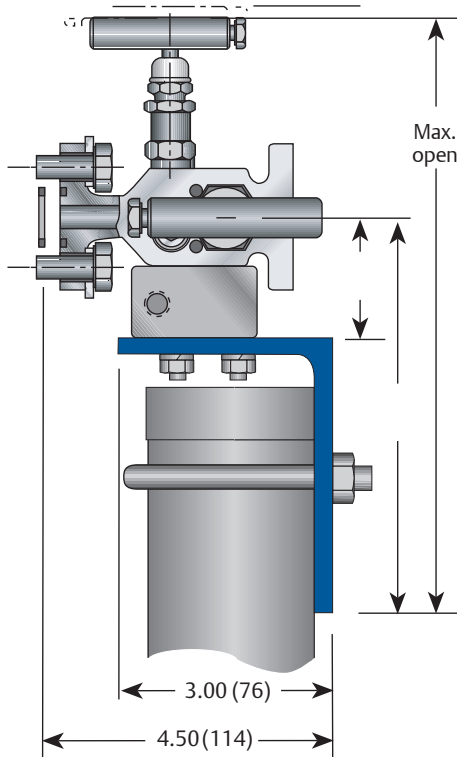

AGCO Mount Kits

Manifold style	Model suffix	Material	Description
M45A ^[1]	AM	CS ^[2]	Standard kit
M45A ^[1]	AMS	316 SS	SS components

NOTES

1. Zinc TCP plated

Features and Benefits

- Lowers maintenance costs by simply removing four transmitter bolts, disconnecting signal leads and performing needed transmitter maintenance.
- Reduces potential environmental contamination and the possibility of signal-line damage.
- Reduces pipestand corrosion by using the bracket overhang and plastic rain hat to cover the pipestand.
- Optional steam heat block permits tracing the manifold and transmitter from a common connection.
- Shipped ready for assembly and installation; includes optional heat block and purge ports (if specified).
- AGCO Mount system is essentially free if you get credit from the transmitter company for the mounting bracket and futbol connectors.

Bonnet Lock (BL) (Patented)

- Anderson Greenwood's Bonnet Lock prevents accidental loosening of the bonnet-to-body seal.
- A high-strength, short bonnet pin aligns a hex collar over the bonnet. A standard panel nut (GRAFOIL® packed) then locks the collar against the valve.
- Tests indicate the minimum torque required to break the collar loose is greater than the torque required to twist off handle.
- Available on GRAFOIL® packed bonnets.

NOTE

1. Standard on power plant manifolds.

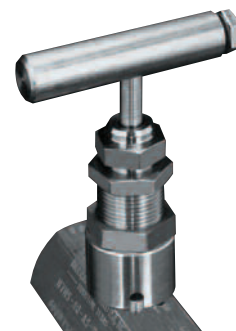

GRAFOIL® Packed Bonnet Lock^[1]

Manifolds - Three Valve

Selection Guide

M45A	V	D	S	-SG	
BASIC SERIES	BONNET PACKING	SEAT	BODY MATERIAL	OPTIONS	
M45A 3-Valve manifold, flange x flange	H GRAFOIL®	D Delrin®	C CS, A576-10L18	AM AGCO Mount kit for 2-inch pipe stand mounting of manifold (see table page 4)	
	V PTFE	E PEEK	J Hastelloy®	BL Bonnet lock device (GRAFOIL® only)	
	R O-ring (FKM) block valve only	K PCTFE	S SS, A479-316	HD Hydrostatic testing (100 percent) (MSS SP-61)	
			S 316 SS	MS Monel® stem (standard on Monel® and SG valves)	
			V PTFE	OC00 Cleaned for oxygen service	
				W SS, A479-316L - maximum pressure 5000 psig (345 barg)	R3V ⁽¹⁾ Add for use with Rosemount® model 3051C (SS 18-8 bolts)
					SSA ⁽¹⁾ 316 SS flange bolt (grade 18-8) - maximum pressure rating 4500 psi (310 barg)
					SSB 316 SS flange bolt (B8M Class 2) - will provide full pressure rating
					SSC ⁽¹⁾ 316 flange bolt (B8M) - maximum pressure rating 4500 psi (310 barg)
					SG (Sour Gas) meets the requirements of NACE MR0175/ISO 15156 (for Chloride conditions ≤ 50 mg/l [ppm]) and NACE MR0103 (SS valves only) (not available for O-ring packed valves)
					SG3 3 (Sour Gas) meets the requirements of NACE MR0175/ISO 15156 (for Chloride conditions > 50 mg/l [ppm])
					TB Test ports - bottom of manifold (1/4-inch FNPT) (option not available for M4A with -AM)
				SS All 316 SS material for non wetted components	

NOTE

1. 316 SS bolts lower pressure ratings to a maximum of 4500 psi [310 barg]. Consult factory for full rating with 316 SS bolts.